

REINER



REINER

www.reiner.de

C, C1, CK, 8, 9, A1

- D** Bedienungsanleitung
- GB** Operating instructions
- F** Mode d'emploi
- E** Manual de instrucciones
- I** Istruzioni per l'uso
- P** Instruções de utilização
- PL** Instrukcja obsługi
- RUS** Руководство по эксплуатации
- دبی** شیوایہات انشئوچیہا



Vielen Dank, dass Sie sich für ein Original
REINER Produkt entschieden haben.

Thanks a lot for making your mind for an
original REINER product.

Merci infiniment d'avoir choisi un produit
Original REINER.

Muchas gracias por haberse decidido por
un producto original de REINER.

Vi ringraziamo per aver optato per un
prodotto originale REINER.

Muito obrigado por ter optado por um
produto REINER original.

Dziękujemy Państwu za to, że zdecydowali
się Państwo na zakupienie oryginalnego
produktu REINER.

Благодарим за выбор оригинальной
продукции REINER.

ششپاڤا څو زېږه ااد سانځا رفرت استوخاوه منښتو
ان ااصاځه REINER

Ernst Reiner GmbH & Co. KG

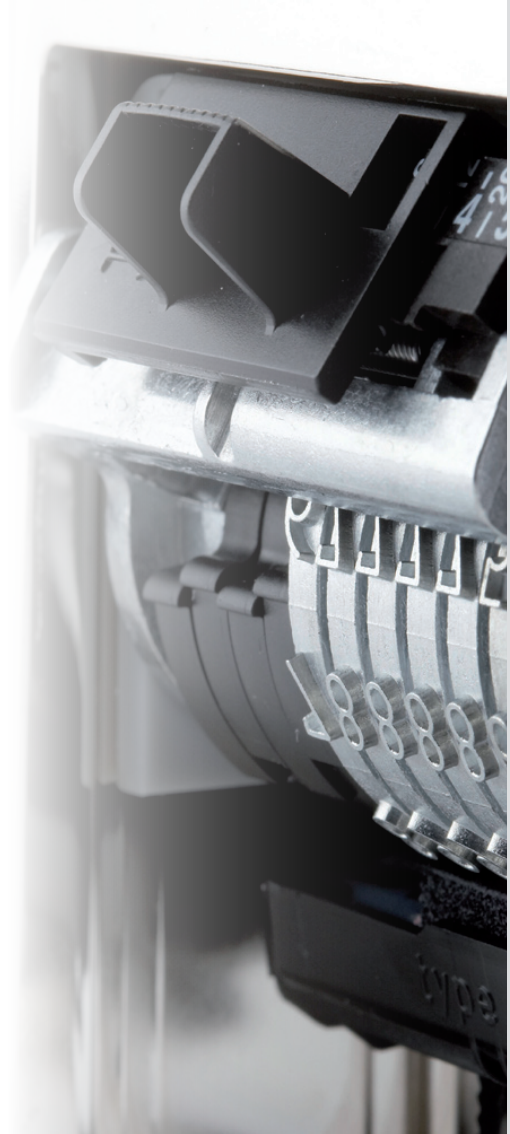

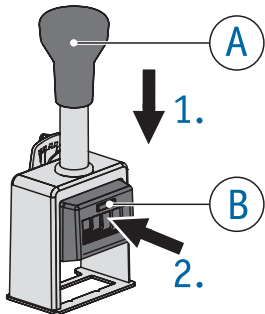
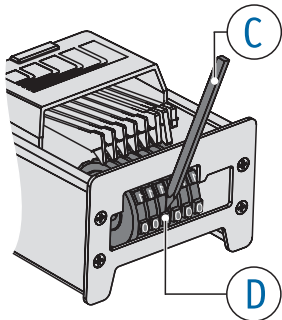
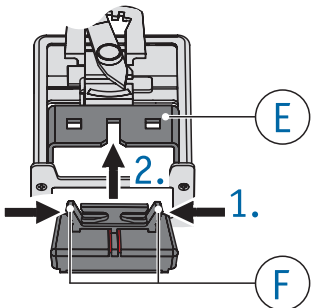
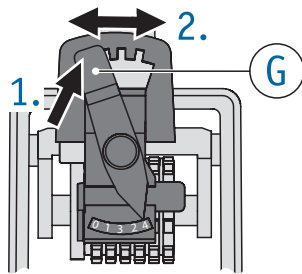
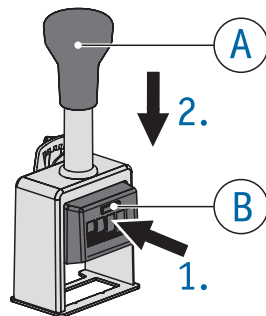
1**2****3****4****5**

To set the stamp wheels ⇒ Fig. 1 + 2

- ▶ Press the handle (A) to the bottom of its travel, then, while still holding it.
- ▶ Press and hold button (B) on the front plate.
- ▶ Allow the handle (A) to move upwards until the handle locks in place.
- ▶ You will be able to move the stamp wheels (D) freely with the stylus (C).

You can hide preceding zeros in a number!
(Not valid for the stamp Model CK.)

Example:	49	instead of	000049
-----------------	----	------------	--------

- ▶ Turn the stamp wheel (D) with stylus (C) to digit position "0".
 - ▶ Using stylus (C) rotate and push down on stamp wheel (D) through a half digit position until it sinks below print height.
 - ▶ To return to the print position, simply push down on handle (A).
-
- ▶ Any wheel which has been 'sunk' will automatically be brought to print height as the numbering sequence progresses. 'Sunk' wheels can be brought into play by simply rotating them further (ie. push towards figure 1.).

To insert the inkpad ⇒ Fig. 1 + 3

Handle with caution to avoid dirt from ink!

- ▶ Press the handle (A) to the bottom of its travel, then, while still holding it.
- ▶ Press the button (B) on the front plate and continue to hold it.

- ▶ Allow the handle (A) to move upwards until the handle locks in place.
- ▶ Unpack the inkpad carefully.
- ▶ Squeeze the grips (F) on the back of the inkpad and hold them.
- ▶ Resting the back of the ink pad inside the pad cradle slide the pad into the slot (E) of the stamp.
- ▶ In order to return to the print position, simply push down on handle (A).

To change the numbering actions ⇒ Fig. 4

Actions	
0	The same number is stamped every time.
1	Number increases after each stamping process.
2	Number increases after every 2 nd stamping process.
	etc.

- ▶ Raise the Action selector lever (G) and move it to the desired action.

To park the stamp ⇒ Fig. 5

To prolong the life of the inkpad, park the stamp!

- ▶ Press and hold button (B) on the front plate.
- ▶ Gently push handle (A) downwards until the stamp clicks & locks in a raised position.
- ▶ In order to return to the print position, simply push down on handle (A).